

DUDLEY Tri-Shell[®] TURBO[™]



HEAVY DUTY CISTERN WITH WATER-SAVING*

DUDLEY Duoflush[™]



Product Description

The market leading Dudley Tri-Shell is a heavy duty plastic cistern with unsurpassed strength.

With almost two million installations, the vandal resistant Tri-Shell has established an unrivalled reputation for trouble free operation whilst withstanding the hardest treatment.

An advanced manufacturing process known as sandwich foam moulding gives the cistern shell a rock hard cellular core. In addition to providing exceptional strength, this greatly reduces the cistern's weight. Furthermore, the improved insulation helps reduce surface condensation.

The cistern comes with a durable high gloss finish and is supplied with a number of vandal resistant features including a lid that is secured by metal screws and a strong metal lever or chain pull.

The Tri-Shell is fitted with a Dudley Turbo 88 2-part convertible syphon as standard. The Turbo 88 has provided reliable and efficient flushing for many years and has now been enhanced with the addition of Dudley Duoflush. This provides dualflush (full and reduced flushing) capabilities when fitted in 9, 7 and 6 litre installations*.



Uses

Wherever high or low level heavy duty cisterns are required, the Tri-Shell provides a proven solution.

When installed in the traditional manner at low level (main photograph above) the cistern is perfect for use in domestic bathrooms, housing developments, hotels and commercial washrooms alike. It is also widely specified in the public sector for installation into schools, hospitals, prisons, and Government establishments.

The water-saving benefits provided by the Dudley Turbo 88 Duoflush syphon make the Tri-Shell a popular choice in commercial and local authority applications where the need to reduce water consumption is becoming increasingly important.

The high level version (inset 2 above) is ideal for most applications where there may be potential for heavy wear or misuse.

An automatic Tri-Shell (inset 3 above) is available in 4.5, 9 and 13.5 litre capacities for use with commercial urinals.

With its installer friendly design, the Tri-Shell has long been the installer's preferred heavy duty cistern for both new installations and the replacement market.

*When fitted in accordance with the Water Supply Regulations 1999

DUDLEY Tri-Shell[®] TURBO[™]



HEAVY DUTY CISTERN WITH WATER-SAVING* DUDLEY Duoflush[™]

Special Features

Exceptional durability and reliability have made the Tri-Shell the leading vandal resistant heavy duty plastic cistern.

The cistern body is made from a very hard cellular core fused between an inner and outer layer. The result is a material that gives unrivalled strength and durability.

1 Inner Layer

2 Outer Layer

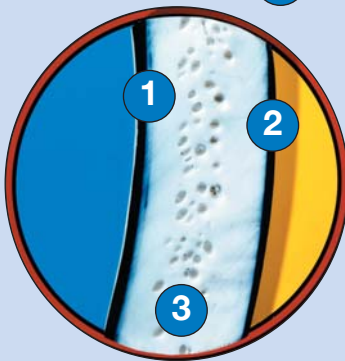

3 Unique, exceptionally strong cellular core

A lid secured by metal screws and robust metal flushing lever or chain enable the cistern to be fitted with confidence into areas that are subject to vandalism.

The Tri-Shell has an aesthetically pleasing high-gloss finish. This makes it ideal for use in domestic bathrooms where appearance is often very important.



The Tri-Shell comes with an internal/external overflow warning pipe and can be supplied with side or bottom connections.

A Dudley Turbo 88 Duoflush syphon completes the package. Supplied as standard, this comes with a patented 2-part design enabling servicing to be carried out in a matter of minutes without the need to disconnect the water supply and dismantle the cistern. Furthermore, the water-saving 6/7/9 litre convertible syphon provides dualflush (full and reduced) flushing that complies with the Regulator's Specification.

A quiet Dudley Hydroflo equilibrium float valve can be supplied as an optional extra. Each Hydroflo valve comes with a lay flat silence tube for extremely quiet filling and a unique key for simple and safe removal of the filter.



Technical Information

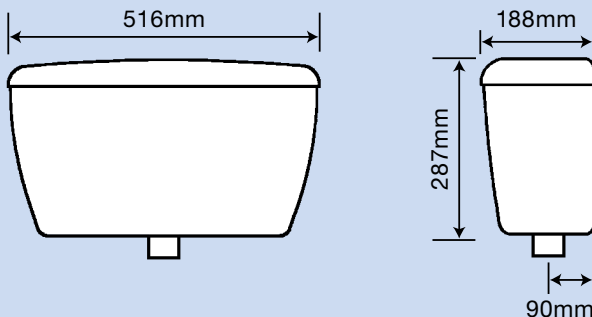

- Uniquely constructed cistern body for unbeatable strength and durability
- Lid held securely in place by metal screws
- Durable metal lever or chain pull
- Durable high gloss finish
- 6/7/9 litre convertible Dudley Turbo 88 Duoflush syphon as standard provides full and reduced flushing capabilities*
- Internal/external overflow warning pipe
- Side connections as standard, optional bottom connections
- Suitable for high and low level installations (high level comes with concealed spacing brackets for use with standard flushpipe with 114mm (4½") top offset)
- Unrivalled track record with almost two million installations
- *Internal parts comply with the Regulator's Specification



DUDLEY Tri-Well™ TURBO®

Well Bottom Heavy Duty Cistern



White
compliments
other washroom
sanitaryware
finish

COMPLIES WITH
REGULATOR'S
SPECIFICATION



Product Description

The Dudley Tri-Well is a unique heavy duty well bottom cistern. It is available in traditional glossy black or glossy white to compliment other washroom sanitaryware.

The body of the Tri-Well is manufactured using the sandwich foam moulding process that produces the Dudley Tri-Shell, a cistern boasting almost two million successful installations. This gives unsurpassed strength and durability, enabling the Tri-Well to withstand the hardest of treatment.

Furthermore, the Tri-Well is lighter and easier to handle than traditional hard rubber alternatives, it is frost resistant and the improved insulation helps reduce surface condensation.

The cistern comes with a durable high gloss finish and is supplied with a number of vandal resistant features including a lid that is held securely in place by metal screws and a strong metal lever and chain pull. A Dudley Turbo S1-11 2-part syphon is supplied as standard and this can be serviced in around five minutes.

The Tri-Well with plastic outlet and nuts improves on the Rubber Well hard rubber cistern. It is also available with brass outlet and nuts as an optional extra, where it provides the ideal replacement for Rubberline and cast iron well bottom cisterns.

Uses

The Tri-Well is designed to fit in the place of rubber and cast iron well bottom cisterns. Existing brackets and pipework can normally be utilised, removing the need to make costly plumbing alterations.

It is perfect for use in domestic toilets as well as hospitals, schools, prisons, leisure centres, factories and other commercial or public washrooms that may be heavily used.

The 6/7/9 litre convertible Dudley Turbo S1-11 2-part syphon can be serviced in a matter of minutes without having to disconnect the water supply and dismantle the cistern. This is particularly beneficial in public installations where it is not practical to leave WCs out of service for long periods of time.

The Tri-Well is available from most plumbers merchants and is ideal for new installations and the replacement market.

Furthermore, the glossy finish allows the cistern to be teamed with a chrome plated flushpipe and decorative brackets for an "antique" style finish (see inset right). These can be supplied by Thomas Dudley Ltd.





DUDLEY Tri-Well TURBO™

Well Bottom Heavy Duty Cistern

Special Features

The heavy-duty Tri-Well incorporates many vandal resistant features, making it an automatic choice for all public washrooms.

The cistern body is made from a very hard cellular core fused between an inner and outer layer. This results in a material that gives unrivalled strength and durability.

With a lid that is secured by metal screws to protect the internal components and a strong metal lever and chain pull, the cistern is ideal for applications that may be subject to vandalism.

The Tri-Well has an aesthetically pleasing and durable glossy finish. The white option now provides the opportunity to specify a well bottom cistern that matches the other sanitaryware in a washroom.

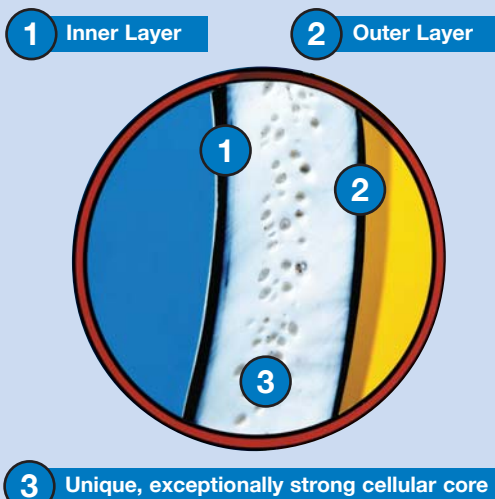

Turbo S1-11 2-part syphon enables 5-minute servicing



Syphon body can be removed from cistern leaving down leg in position.



Servicing can then be carried out without turning off water and dismantling cistern.



Technical Information

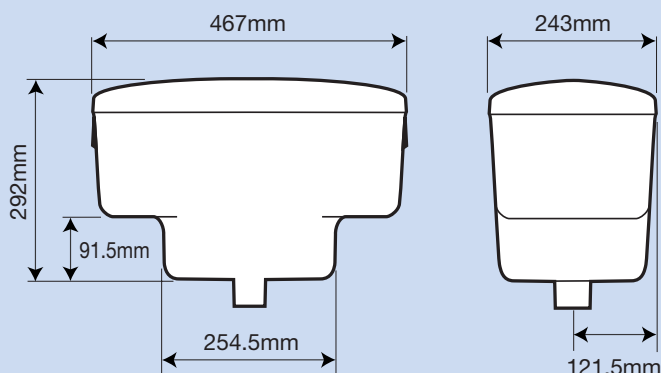

- Available in white or black
- Uniquely constructed body for unbeatable strength and durability
- Frost resistant
- Lid held securely in place by metal screws
- Strong metal lever and chain pull
- Durable glossy finish
- 6/7/9 litre convertible Turbo 2-part syphon
- Internal/external overflow warning pipe
- Side connections
- Plastic outlet tail and nuts as standard (brass outlet tail and nuts available as an optional extra)
- Semi-concealed support brackets available as an optional extra
- Internal parts comply with the Regulator's Specification