

DUDLEY Pushbuttons

ROYAL BUTTON SINGLE FLUSH

See section 1.1

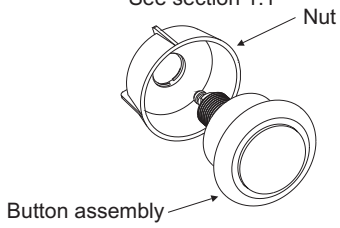

EXTENDED ROYAL BUTTON SINGLE FLUSH

See section 1.2

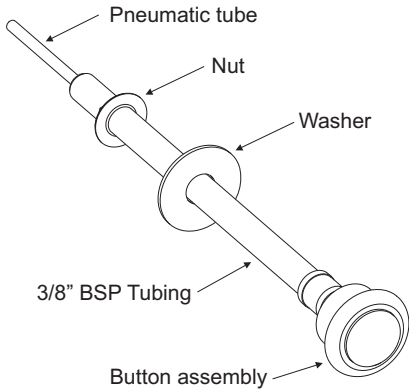

DIO BUTTON - DUAL FLUSH

See section 1.3

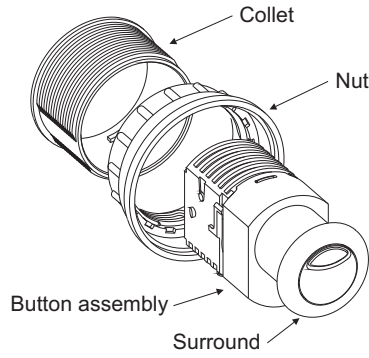

MINIFLO BUTTON - DUAL FLUSH

See section 1.3

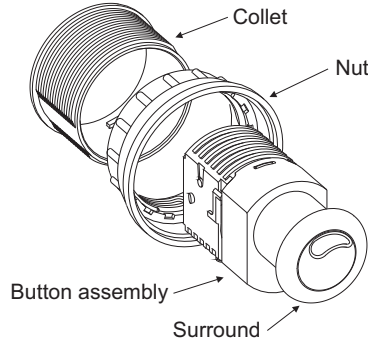

Ø73.5mm PNEUMATIC BUTTON SINGLE AND DUAL FLUSH

See section 1.4

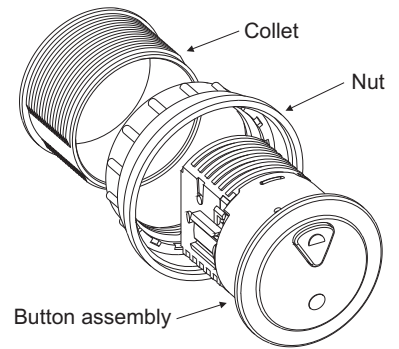
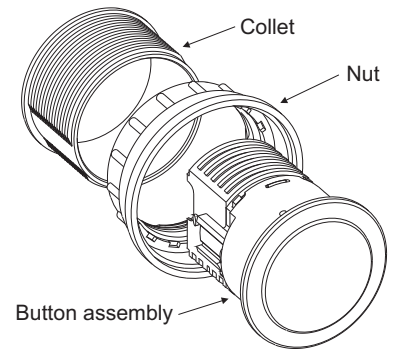

1 - Fitting -

1.1 Royal button

1.1.1 Mark position of button ensuring there is no interference with cistern, support frame etc.

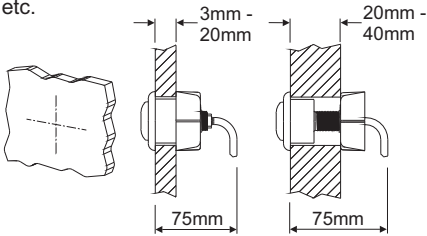

1.1.2 Cut hole.

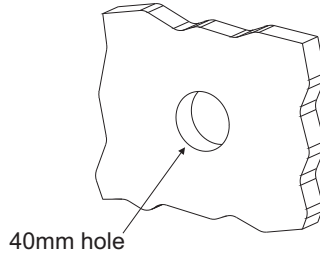

1.1.3 Fit button assembly into panel and clamp in position with nut.

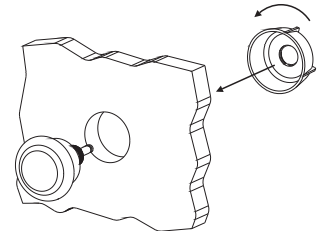

Move to section 2.

1.2 Extended royal button

1.2.1 Mark position of button ensuring there is no interference with cistern, support frame etc.

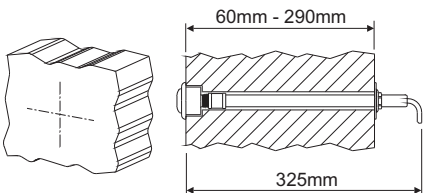

1.2.2 Cut counterbore and hole.

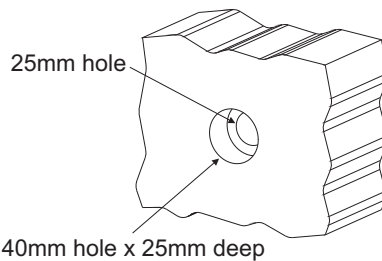

1.2.3 Fit assembly into wall.

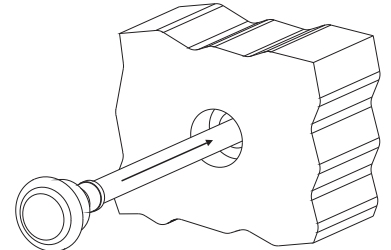

1.2.4 Locate washer over tubing, attach nut and tighten until assembly is clamped in position.

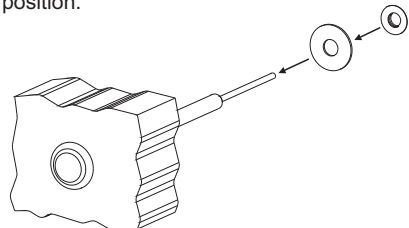

Move to section 2.

1.3 Dio and Miniflo button

1.3.1 Mark position of button ensuring there is no interference with cistern, support frame etc.

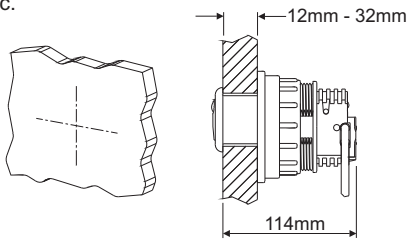

1.3.2 Cut hole.

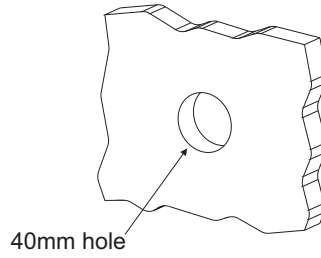

1.3.3 Fit button assembly into panel and attach surround.

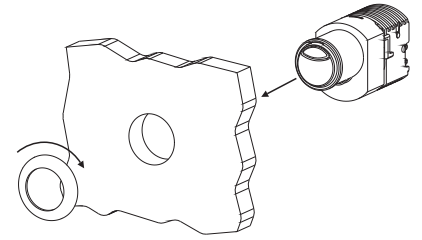

1.3.4 Screw collet into nut.

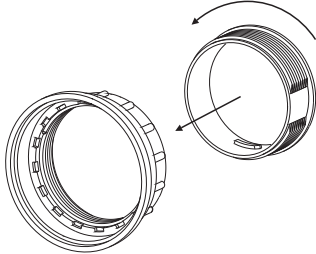

1.3.5 Locate collet and nut assembly into the slots on the button assembly.

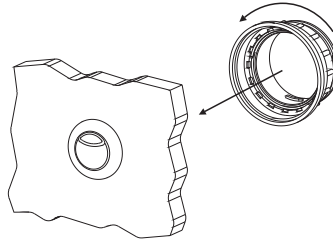

1.3.6 Tighten nut until assembly is clamped in position.

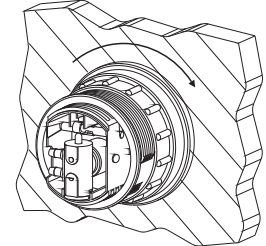

Move to section 2.

1.4 Ø73.5mm pneumatic button

1.4.1 Mark position of button ensuring there is no interference with cistern, support frame etc.

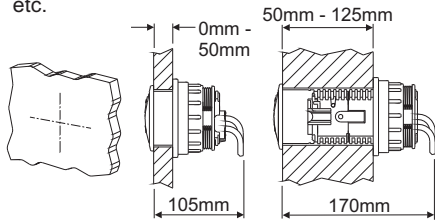

1.4.2 Cut hole.

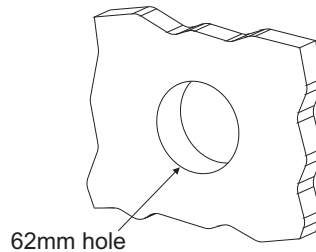

1.4.3 Screw collet into nut.

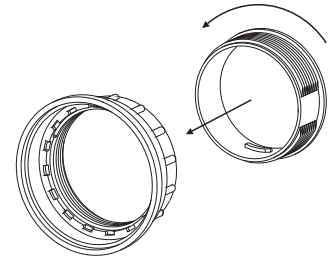

1.4.4 Fit button assembly into panel and locate collet and nut assembly into the slots on the button assembly.

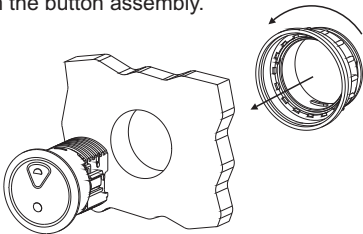

1.4.5 Tighten nut until assembly is clamped in position.

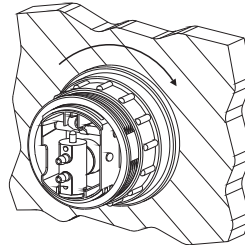

Move to section 2.

2 - Connecting pneumatic tubes -

2.1 Dual Flush - Cut pneumatic tubes to the minimum working length. Ensure tubes are not kinked or stretched.

Clear tube = full flush.

Green tube = partial flush.

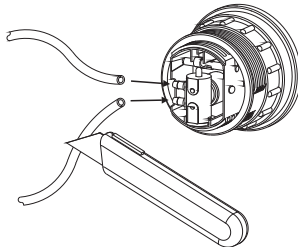

2.2 Single flush - Cut pneumatic tube to the minimum working length. Ensure tube is not kinked or stretched.

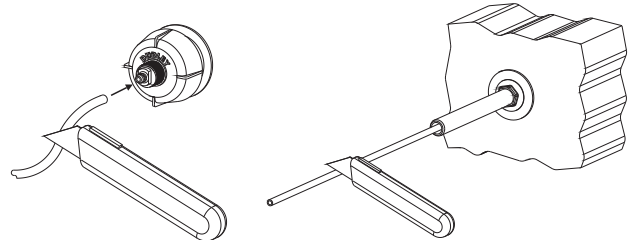

3 - Operation -

3.1 Dual Flush - On reduced flush the large button will also travel when the small button is pressed. Allow time for cistern to fill before flushing.

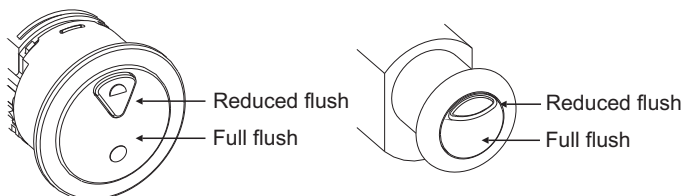

Note - the buttons may return slowly after operation, this is quite normal.



Thomas Dudley Ltd

PLASTIC CISTERN MANUFACTURERS

Dauntless Works, P.O.Box 28,
Birmingham New Road, Dudley,
West Midlands, DY1 4SN

Telephone: 0121 530 7000

Fax: 0121 557 5345

E-mail: sales@thomasdudley.co.uk