

INTERNAL COMPONENTS FITTING INSTRUCTIONS

Please read these instructions fully before starting installation.

WARNING

No sealing compound, paste, flux or solvent to be used in contact with plastic or rubber surfaces, to avoid damage to plastic components. Rubber washers should provide adequate seal. PTFE tape may be used on threads. Do not overtighten plastic nuts.

Although every effort is made to ensure this product reaches you in good condition - before fitting please check for any possible damage that may have occurred since leaving our factory, and that all parts are present against the instruction leaflet before commencing any part of the installation.

All Syphons. (To convert Turbo 88 to Duoflush see separate instructions)

Fit syphon with rubber washer inside cistern. Secure with 1.1/2" BSP back nut (1A). Before fixing the cistern to the wall, it is advisable to fit remainder of internal components. Insert flush bend into tail of syphon with thin cone (compression) ring in place. Hand tighten cap nut. Depending on the height of cistern from floor, it may be necessary to cut flush bend. Remove traces of burr. No more than 50mm (2") to be inserted into syphon down leg. **(Fig.1)** *Note!* Where required, the Lid screw and screw boss extension piece, are stored in downleg web for transit purposes.

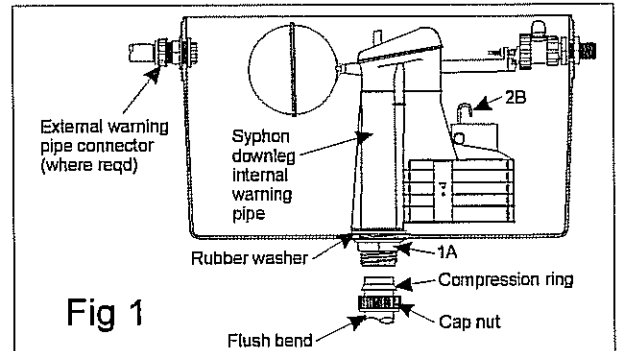

Fig 1

All Outlet Valves.

Fit the outlet valve as per the instructions supplied with the outlet valve with the addition of the bowl which is located between the valve and the cistern with a rubber washer either side of the bowl for sealing against leakage. **(Fig. 2)** The height of the bowl is predetermined to suit the amount of water your cistern will deliver to the pan to give efficient pan clearance.

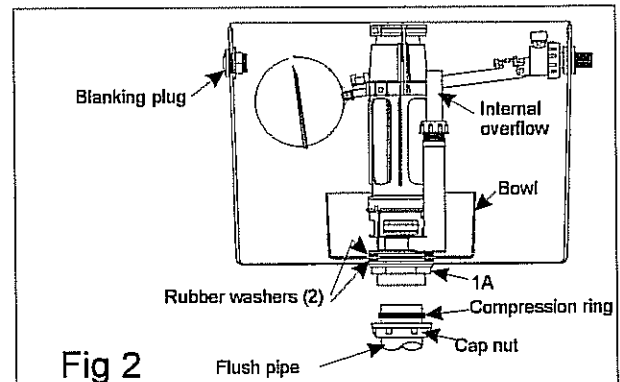

Fig 2

Ball Float Valves

Both side entry and bottom entry types are fitted with 3mm(1/8") bore high pressure (white) seat to suit mains water supply. A low pressure 6mm(1/4") bore (red) seat is also provided for use only when the cistern is fed from low pressure supply i.e. storage tank.

Screw float firmly onto end of arm before fitting valve. Set float position after fitting in cistern if swivel arm is fitted (6B) **(Fig.3)**.

Side entry.

Screw a spigot nut onto the tail with spigot side facing inwards. Locate rubber washer between nut and cistern wall. Tighten second spigot nut with spigot towards cistern to centralise valve in hole.

Important. Make certain float arm moves freely in a vertical path.

Push overhead discharge elbow (6C) **(Fig. 3)** onto top outlet and turn inwards. In the case where the valve is used with a syphon, make sure the water from the overhead discharge elbow is not directed into the reservoir on the syphon. (6A) **(Fig.3)**

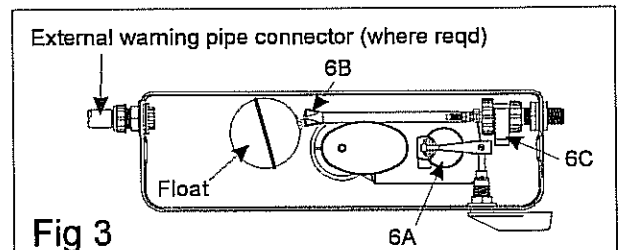

Fig 3

Pedestal bottom entry.

Fit pedestal float valve through base of cistern with rubber sealing washer inside. Secure using spigot back nut pointing inwards to locate the pedestal centrally in the cistern hole. Position pedestal to ensure free movement of the ballarm. Adjust the pedestal bracing stay so that it touches wall of cistern and tighten locknut. **(Fig. 4)**

Equilibrium Valves.

Follow the instructions supplied with the valve.

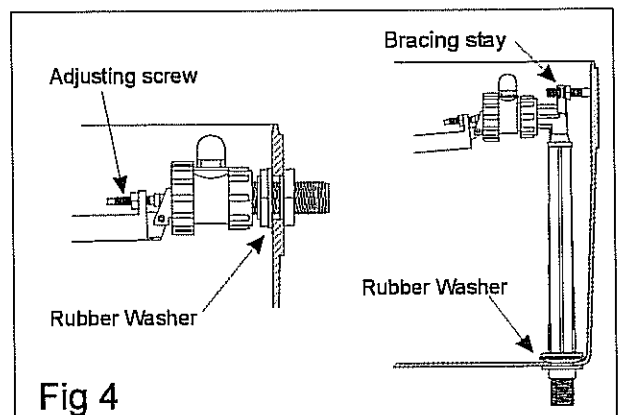

Fig 4

Internal Overflow Warning.

If internal overflow warning is required, seal external warning pipe hole in side or bottom of cistern with plug and sealing washer. (Fig. 5). Discard external warning pipe connectors.

External Overflow Warning Pipe.

Side entry.

TD straight warning pipe connector is fitted from inside the cistern and secured with flange nut (Fig. 5). Elbow version is fitted from outside and secured with flange nut.

Bottom entry.

Fix angled warning pipe through base of cistern with rubber sealing washer inside. Turn angle of pipe to corner of cistern to allow clearance for ball float arm movement, if fitted. Tighten back nut (Fig. 5)

Lever Assembly.

Secure lever shaft with plastic back nut. (Fig. 6) Connect 'C' link (2B) (Fig. 1) to lift arm (3C), then slide arm onto lever shaft and tighten screw. Ensure lift arm is in line with 'C' link and piston plunger rod. Ensure free movement of cistern lever. For curved front cisterns use the two wedge shaped collars (4D) provided and secure with plastic back nut (5C) (Fig. 6)

Close-coupled installation (using fixing plate)

Fit syphon or outlet valve as described earlier but add coupling plate between the cistern and back nut. Ensure coupling plate is parallel to rear of cistern.

Push rubber sealing washer over back nut (shape of washer varies according to w.c. pan type). Slide bolts into coupling plate slots. Gently lower cistern onto w.c. pan, guiding bolts through holes. Fix securely using washers and wing nuts. (Fig 7)

Close-coupled installation (cistern directly onto w.c. Pan)

Fit syphon or outlet valve as described earlier. Insert the two bolts together with the washer arrangement (Fig 8) through the base holes in the cistern. Fit washers and tighten lock nuts. Push the close-coupling sealing washer over the back nut (shape of washer will vary according to w.c. pan type).

Gently lower the cistern onto w.c. pan guiding the bolts through holes and tighten cistern onto pan using wing nuts and washer arrangement. (Fig 8)

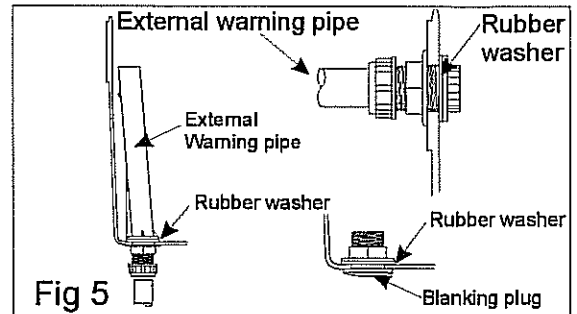

Fig 5

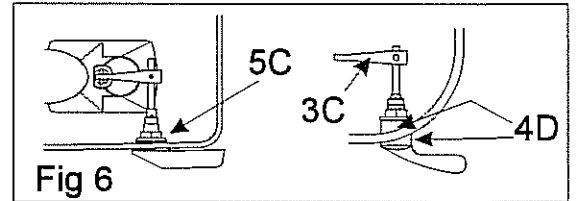

Fig 6

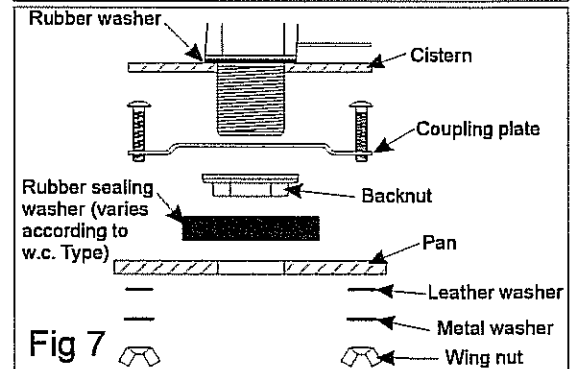

Fig 7

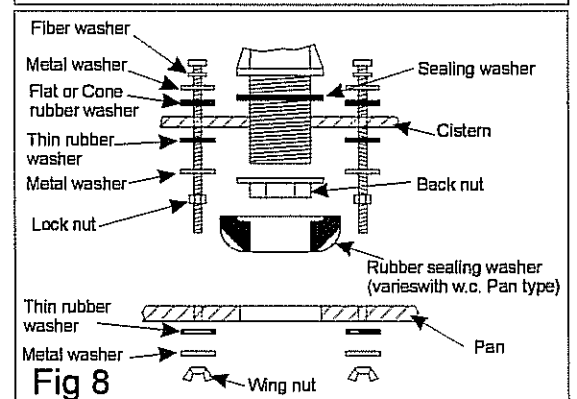

Fig 8

FINAL CHECK LIST

Before turning on water supply check :-

**CISTERN IS SECURE -
ALL MOVING COMPONENTS OPERATE FREELY -
ALL JOINTS ARE TIGHTENED CORRECTLY**

Now fill cistern and set water level.

**CHECK CAREFULLY FOR LEAKS -
ENSURE ALL MOVING COMPONENTS OPERATE FREELY -
CHECK FLOAT ARM MOVES FREELY UP AND DOWN AND
CLOSES OFF CORRECTLY -
TEST SYPHON / OUTLET VALVE OPERATION AND THAT
CISTERN FLUSHES CORRECTLY**

Water level

Set the float arm adjusting screw (or the float on a equilibrium valve) so that the water level is initially 13mm (1/2") below level marked on inside of cistern to allow for variations in mains water pressure particularly during the night. Tighten locknut to secure adjusting screw (Fig.4) in the case of a ball float valve. If overflowing or poor flushing subsequently occurs, first check that the float arm moves freely up and down then reset the float position. If overflowing continues, check internal assembly and remove any foreign matter or clean filter.

We reserve the right to revise this specification and details without notice.



Thomas Dudley Ltd

PLASTIC CISTERN MANUFACTURERS

Dauntless Works, P.O.Box 28, Birmingham New Road, Dudley,
West Midlands, DY1 4SN

Telephone: 0121 530 7000 Fax: 0121 557 5345 E-mail: sales@thomasdudley.co.uk