

DUDLEY MIRAGE™

concealed cistern



1



3

Product Description

The Dudley Mirage is a concealed cistern that has been developed to meet the needs of most ducted installations.

Its compact design makes it ideal for use in ducts and behind partitions where it can be installed at high, medium and low levels to suit the individual requirements of each application.

The cistern is often specified for use in pre-fabricated factory built pods and is compatible with most modern construction techniques.

Made from high-impact polystyrene, the lever-operated Mirage comes with a convertible syphon for 6/7/9 litre flushing that complies with the Regulator's Specification. An internal/external overflow warning pipe enables the Mirage to be used in either situation.

With over one million successful installations, the installer-friendly Mirage has established an unrivalled reputation for reliability.

DUDLEY Duoflush

A one piece Dudley Duoflush syphon is supplied as standard.

A 2-part Dudley Turbo 88 Duoflush syphon, which can be serviced in under five minutes, is available as an optional extra. Both syphons provide full and water-saving reduced flushing in low level installations*.



Uses

Wherever high, medium or low level concealed WC cisterns are required, the Mirage provides an extremely reliable and simple-to-install solution.

A comprehensive range of vandal resistant metal lever kits can be supplied for use with partitions from 12mm thick (main photograph above) up to 365mm thick walls (inset 3 above). The Mirage is also available with electronic flushing.

The cistern can be screwed directly onto most wall and partition materials when used in the traditional manner with floor mounted WC pans.

The Mirage is also ideal when used in conjunction with wall-hung WC pans and support systems such as the Dudley Sentinel bracket (inset 4) and Dudley Illusion Universal, Compact Universal and Freestanda frames.

An automatic version is available in 4.5, 9 and 13.5 litre capacities for use with commercial urinals.

For a push button operated concealed cistern, please refer to the Dudley Pushflo. The Dudley Vantage concealed cistern provides a solution that has been designed specifically for fitted bathroom furniture.

4



* When fitted in accordance with the Water Supply Regulations 1999.

DUDLEY MIRAGE™ concealed cistern



Special Features

Combined durability and affordability have made the Mirage the installer's favourite concealed cistern.

Installation Examples

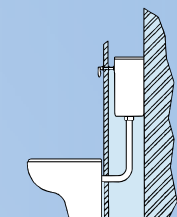

Rear wall fixing behind partitions with traditional back-to-wall WC pan

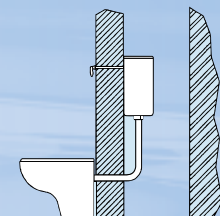

Front or rear wall fixing behind walls with traditional back-to-wall (or wall-hung) WC pan

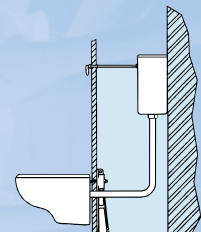

Rear wall fixing behind partitions with Dudley Sentinel brackets, Illusion frames and wall-hung WC pan

The Mirage can be easily screwed onto most materials and is also ideal for use with wall-hung WC pan support brackets and frames.

It can be supplied with a comprehensive range of lever kits to fit partition/wall thicknesses from 12-365mm.

Each vandal resistant metal lever comes with a stop which prevents the lever from being rotated backwards. This enables the Mirage to be installed with confidence into public areas where there is the potential for misuse.

	Wide range of lever kits		
	Lever Spindle Length	Effective Lever Bush Length*	Partition/Wall Thickness
Lever Kit P	115mm	80mm	12-65mm
Lever Kit W	225mm	160mm	12-145mm
Lever Kit A	325mm	260mm	12-245mm
Lever Kit B	430mm	368mm	22-365mm

The Mirage comes with an internal/external overflow warning pipe and can be supplied with side or bottom connections. It is operated by a 6/7/9 litre convertible plastic syphon.

For easy flushing by the less able, the Mirage can be operated by a Dudley Dimple lever.

A quiet Dudley Hydroflo equilibrium float valve can be supplied as an optional extra. Each Hydroflo valve comes with a lay flat silence tube for extremely quiet filling and a unique key for simple and safe removal of the filter.



Technical Information

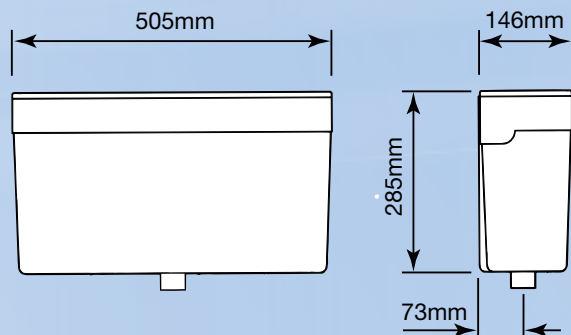

- Saves water - Dualflush supplied as standard
- Cistern body constructed from high-impact polystyrene
- Suitable for high, medium and low level installations
- 6/7/9 litre convertible syphon
- Can be supplied with a 2-part Dudley Turbo 88 Duoflush syphon
- Internal/external overflow warning pipe
- Side connections as standard, optional bottom connections
- 457 x 305mm tight radius flushbend
- Lever operated
- Internal parts comply with the Regulator's Specification